

# INSTALLATION INSTRUCTIONS FOR MODEL H00962EA

IMPORTANT: REVIEW ALL INSTRUCTIONS, PARTS LISTS, & INSTALLATION DIAGRAMS  
BEFORE STARTING INSTALLATION

## HORN ASSEMBLY

1. For best results, mount horns in an unobstructed opening for sound to carry straight ahead. If possible mount horn with slight downward angle to allow moisture to drain out.
2. For roof mount installation: If vehicle is equipped with interior roof trim panel, remove to install horn.
3. Drill 1/2 in. and 11/32 in. holes (use mounting pad for template, item# 4) in position desired for horn.
4. Place mounting pad between base of horn and top of vehicle roof.
5. Place tensions washer (item# 5) on lanyard (item# 6) as shown in figure 1, next thread the lanyard into the base of the horn from under the roof. Insert screw (item# 7) through hole of horn base and roof, attach lock washer (item#10) and hex nut (item# 9). Connect nylon tubing (item# 11) to lanyard using brass insert (item# 7) and tube nut (item# 8) and run tube down to tank location. Replace trim panel.

(**Optional Step 5**) Mount lanyard valve (item# 6) to bracket (item# 32) using jam nut (item# 31) as shown in figure3. Attach lanyard bracket to desired location using (2) self-tapping screws (item# 33). Place tension washer (item# 5) on mounting elbow (item# 30), next thread the elbow into the base of the horn from under the roof. Insert screw (item# 1) through hole of horn base and roof, attach lock washer (item# 10) and hex nut (item# 9). Connect nylon tubing (item# 11) first to mounting elbow and then to lanyard valve. Next connect tubing to lanyard and run tube down to tank location. Replace trim panel.

## TANK ASSEMBLY

1. Select mounting location for air tank (item# 22) keeping in mind the orientation of the tank and visibility of the air gage. (See Figure 1 for sample installation)
2. Thread brass fitting (item# 16) into brass cross (item# 14), then install into either tank outlet. Next thread other brass fitting (item# 15) into brass cross. Connect nylon tubing from lanyard valve supply (item# 6) using brass insert (item# 7) and tube nut (item# 8), In remaining (2) outlets of the brass cross, thread tire valve (item# 12) and brass fitting (item# 15).
3. Thread brass tee fitting (item# 18) into remaining tank outlet. Thread the pressure gage (item# 17) and pressure switch (item# 19) into the tee.

**CAUTION:** Tighten pressure switch and pressure gage on brass hex body only.

4. To mount tank drill (2) 11/32 in. diameter holes spaced 4 in. apart in a rigid surface. Insert tank studs through the holes and secure with locknuts (item# 21).

## COMPRESSOR ASSEMBLY

1. As shown in figure 2, slide the (2) grommets (item# 27) into slots. Next push the (2) brass eyelets (item# 26) into the grommets. Pull the (4) bumpers (item# 29) through the (4) round holes on the bracket.
2. Clamp compressor head and install brass fitting (item#15) into air outlet as shown in figure 1.
3. Mount compressor on rigid support. Do not mount on fender well, firewall or other flexible material. Do locate compressor in area with good air flow and away from road surface to avoid excessive water and dirt conditions.
4. Mounting requires (2) holes spaced 2- 3/16 in. apart, each having a diameter of 7/32 in.
5. To mount compressor, insert 10-32 bolt (item# 25) through the brass eyelet and through the 7/32 in. hole. Secure with the 10-32 nut (item# 28) as shown in figure 2. **Do not over tighten mounting bolts.**
6. Connect nylon tubing from air outlet fitting to the brass male connector on the tank as shown in figure 1.

## ELECTRICAL ASSEMBLY

1. As shown in figure 1 connect orange (+) wire from compressor motor to either pressure switch terminal. Next, connect fuse holder (item#23) to the other pressure switch terminal. Install other end of fuse holder to "ignition activated" accessory terminal in fuse panel. Attach motor's black wire (-) to metal ground.

---

**NOTE:** Compressor starts automatically when pressure drops below 110 psi. If more than 4 minutes are required to pump tank to full pressure (110-135 psi) with engine running and compressor does not shut off, check all connections with soapy water or bubble solution for leaks. Use thread sealant on all uncoated pipe threads. Maximum cycle time 7 minutes with 30 minute cool down.

---

**CAUTION:** Check local noise abatement ordinances to avoid legal violations.

# INSTALLATION INSTRUCTIONS FOR MODEL H00962EA

## INSTALLATION DIAGRAM

FIGURE 1

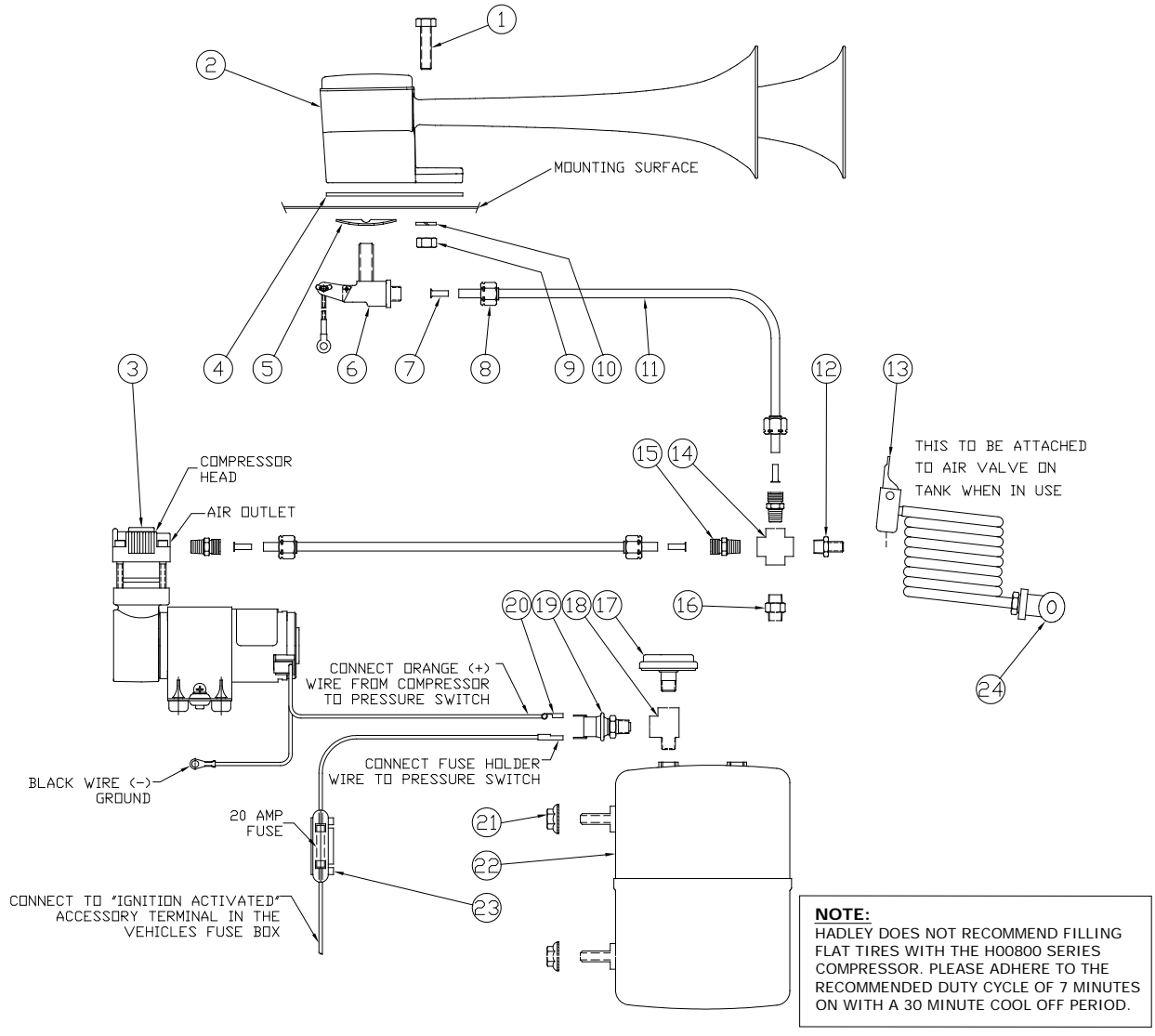

FIGURE 2  
BRACKET ASSEMBLY

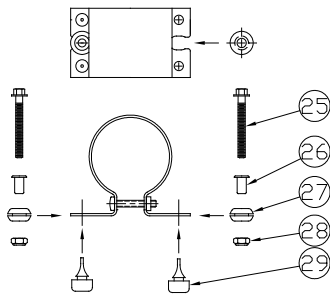
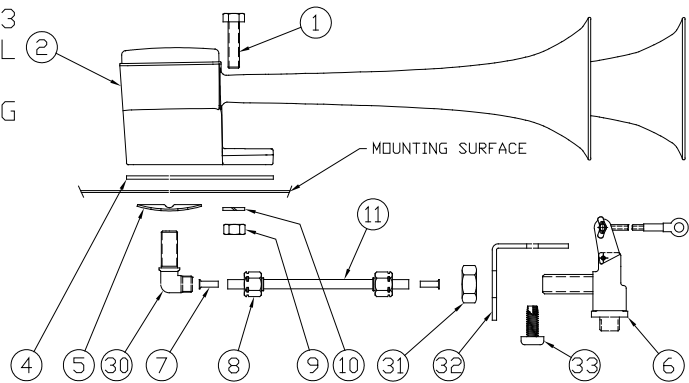
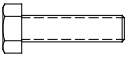

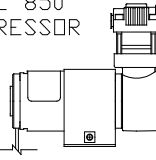
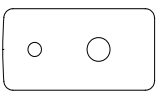

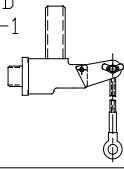





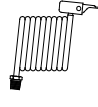



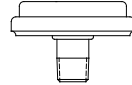
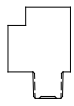
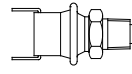

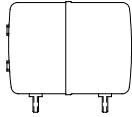
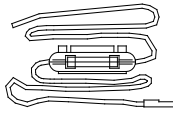





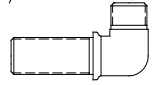

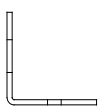



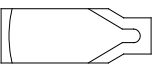

FIGURE 3  
OPTIONAL  
REMOTE  
MOUNTING



# INSTALLATION INSTRUCTIONS FOR MODEL H00962EA

## PARTS LIST

<p>(1)-QUANTITY HEX SCREW H11640</p>  <p>①</p>	<p>(1)-QUANTITY AIR HORN KIT H00910CA</p>  <p>②</p>	<p>(1)-QUANTITY MODEL 850 COMPRESSOR</p>  <p>③</p>	<p>(1)-QUANTITY MOUNTING PAD H16504S</p>  <p>④</p>	<p>(1)-QUANTITY TENSION WASHER H11553</p>  <p>⑤</p>
<p>(1)-QUANTITY LANYARD H00755-1</p>  <p>⑥</p>	<p>(4)-QUANTITY BRASS INSERT H12462</p>  <p>⑦</p>	<p>(4)-QUANTITY TUBE NUT H15522</p>  <p>⑧</p> <p>NOTE: (1) TUBE NUT LOCATED ON LANYARD VALVE</p>	<p>(1)-QUANTITY HEX NUT H10241</p>  <p>⑨</p>	<p>(1)-QUANTITY LOCKWASHER H10236</p>  <p>⑩</p>
<p>(1)-QUANTITY NYLON TUBING 1/4" H13110-13</p>  <p>⑪</p>	<p>(1)-QUANTITY TIRE VALVE H12489</p>  <p>⑫</p>	<p>(1)-QUANTITY HOSE H14106</p>  <p>⑬</p>	<p>(1)-QUANTITY BRASS CROSS 1/8 H11830</p>  <p>⑭</p>	<p>(3)-QUANTITY BRASS FITTING 1/4 X 1/8 H12553</p>  <p>⑮</p>
<p>(1)-QUANTITY BRASS FITTING 1/8 X 1/8 H11468</p>  <p>⑯</p>	<p>(1)-QUANTITY PRESSURE GAGE 0-160 psi H14212</p>  <p>⑰</p>	<p>(1)-QUANTITY BRASS TEE 1/8 H14654</p>  <p>⑱</p>	<p>(1)-QUANTITY PRESSURE SWITCH H13940A</p>  <p>⑲</p>	<p>(1)-QUANTITY FEMALE TERMINAL H14620</p>  <p>⑳</p>
<p>(2)-QUANTITY LOCKNUT 5/16 H12737</p>  <p>㉑</p>	<p>(1)-QUANTITY AIR TANK H00626</p>  <p>㉒</p>	<p>(1)-QUANTITY FUSE HOLDER H15235</p>  <p>㉓</p>	<p>(1)-QUANTITY BALL CHUCK H14200</p>  <p>㉔</p>	<p>(2)-QUANTITY BOLT 10-32 H14168</p>  <p>㉕</p>
<p>(2)-QUANTITY EYELET H15224</p>  <p>㉖</p>	<p>(2)-QUANTITY GROMMET H15234</p>  <p>㉗</p>	<p>(2)-QUANTITY NUT 10-32 H14591</p>  <p>㉘</p>	<p>(4)-QUANTITY BUMPER H14572</p>  <p>㉙</p>	<p>(1)-QUANTITY MOUNTING ELBOW H11477</p>  <p>㉚ (OPTIONAL)</p>
<p>(1)-QUANTITY HEX JAM NUT H11356</p>  <p>㉛ (OPTIONAL)</p>	<p>(1)-QUANTITY LANYARD MOUNTING BRACKET H11978</p>  <p>㉜ (OPTIONAL)</p>	<p>(2)-QUANTITY SCREW, SELF-TAPPING H12395</p>  <p>㉝ (OPTIONAL)</p>	<p>(1)-QUANTITY WIRE 16 GA. H12669-2</p>  <p>㉞</p>	<p>(1)-QUANTITY WIRE SPLICE CONNECTOR H13116</p>  <p>㉟</p>
<p>(1)-QUANTITY TEFLON THREAD SEALANT H13943</p>  <p>㊱</p>				

ECR 4496 REV F  
FILENAME: H13954.DWG

# INSTALLATION INSTRUCTIONS FOR MODEL H00962EA



[www.hadley-products.com](http://www.hadley-products.com)

---

All Hadley products carry a limited warranty for 12 months from date of purchase. We will repair or replace, at our option, defects in material and workmanship during that period when product and proof of purchase are returned to our service department at the address below.

---

Hadley Products  
Attn: Service Department  
2851 Prairie SW, Suite D  
Grandville, MI 49418

Service Department: (616) 249-8462  
Main: (616) 530-1717  
Fax: (616) 530-3283

# MOUNTING TEMPLATES

