



OMNITM INTERIOR SYSTEM

This interior system has been designed for the coach market to offer passenger comfort, sense of spaciousness, and ease of handling and installation by the OEM.

FEATURING

BENEFITS

- Ergonomically designed to give a comfortable and spacious environment
- Lighter weight
- Single bin LED lighting (low power consumption... standard)
- Illuminated handrail stripe - safety
- Optional window lighting
- Optional bungee chords (storage aid)
- LED reading lights (standard)
- Optional 10" & 15" LCD monitors
- Storage: over 100 lbs. per compartment
- Customizable (colors/fabric)
- Optional lockable storage for driver
- Optional upgradable sound system
- Optional wheel chair lift
- Optional luggage rack doors



Global Headquarters

2851 Prairie S.W., Grandville, Michigan 49418
Ph. 616-530-1717 | Fax 616-530-3283

Transit Division

2503 Marina Drive, Elkhart, Indiana 46514
Ph. 574-266-3700 | Fax 574-266-3747

hadley-products.com

MULTISETS AVAILABLE IN VARIOUS CONFIGURATIONS

- 9 LED reading lights that provide a luminous flux of more than 20 foot candle @ reading position
- Air vent (max air outlet opening 1.78 square inches)
- Blue nightlight
- Stop button as optional



OTHER MULTISSET EXAMPLES



NIGHT LIGHT ON HANDRAIL

Electroluminescent stripe, dimmable in intensity, to easily locate the handrail during night travel.



OMNI SYSTEM WITH DOOR

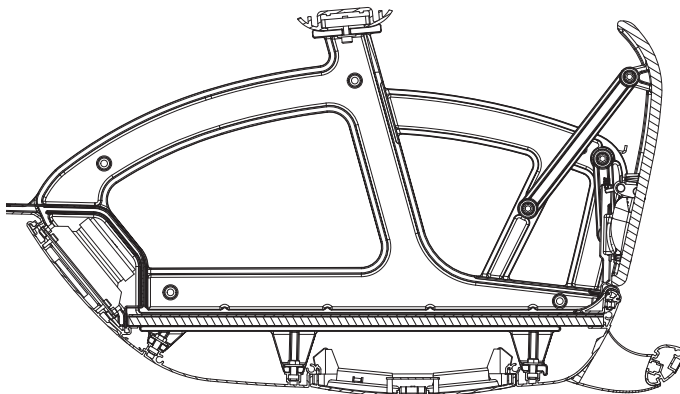

OMNI SYSTEM WITHOUT DOOR

